

Product Change Notice

Date:	March 19, 2021
Overview:	Obsolescence of part number W3G300-BV25-21
Reason for Change:	A component needed to manufacture it is being discontinued
Affected Part No(s):	W3G300-BV25-21
Design Change Detail:	Part number W3G300-BV25-21 is being obsoleted due to the discontinuation of a component needed to manufacture it. The suggested replacement is W3G300- ME48-11.
Effective Date:	Orders can be placed through September 24, 2021 after which this product will no longer be available
Last Time Buy Deadline:	September 24, 2021
Pricing:	No change
ebm-papst employee:	Jeannine Zenobi
Attachments:	Datasheets for part number W3G300-BV25-21 and suggested replacement part number W3G300- ME48-11
Comments:	N/A

DC axial fans

Automotive series W3G300, Ø 300mm



Highlights:

- Control input: 0-10 VDC/PWM
- Load dump (58V)
- Over-voltage detection
- Over-temperature protected electronics
- Soft start, motor current limit, line undervoltage detection
- Over 85C with power derating
- Reverse polarity and locked rotor protection

Material: Impeller: PA plastic
Electronic housing: PA plastic

Mounting position: Any

Condensate discharge holes: None, open rotor

Direction of rotation: Clockwise, seen on rotor

Nominal Data

Type	Motor	Air flow CFM	Voltage VDC	Voltage range VDC	Power input (1) Watts	Speed (1) RPM	Current draw (1) A	Temperature range (1) °C	Mass lbs	Sealed ball bearings	Direction of air flow (intake) rotor	Ingress protection rating (motor) IP 24 KM	Ingress protection rating (electronics) IP 6K 9K
W3G300-BV25-21	M3G084-BF	1897	26	16...32	380	3940	14.6	-40...85/110C	4.4	Yes	V	IP 24 KM	IP 6K 9K

(1) Nominal data at free air.

Curves

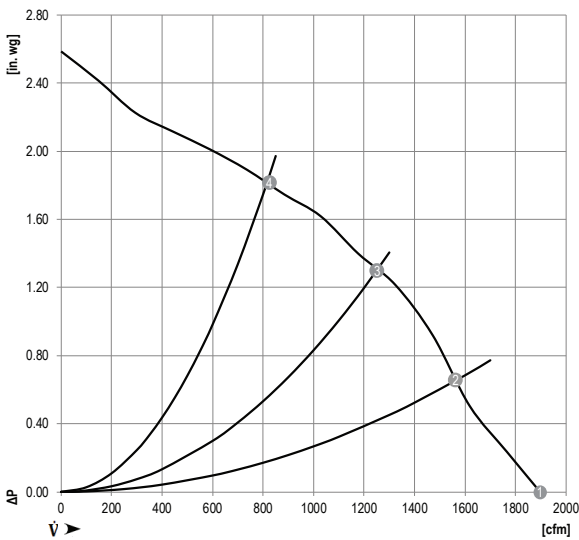

Measurement: LU-141116

Air performance measured as per: ISO 5801, Installation category A, without protection against accidental contact.

Suction-side noise levels: L_wA as per ISO 13347, L_pA measured at 1m distance to fan axis.

The values given are valid under the measuring conditions mentioned and may vary according to the actual installation situation.

With any deviation to the standard set-up, the specific values have to be checked and reviewed once installed or fitted.

For detailed information on the measuring set-up, please contact ebm-papst.

	n rpm	Pe W	I A	L _p A _{in} dB(A)	L _w A _{in} dB(A)
1	3940	380	14.6	79	87
2	3815	408	15.7	79	87
3	3715	462	17.7	78	85
4	3630	495	19.0	81	88

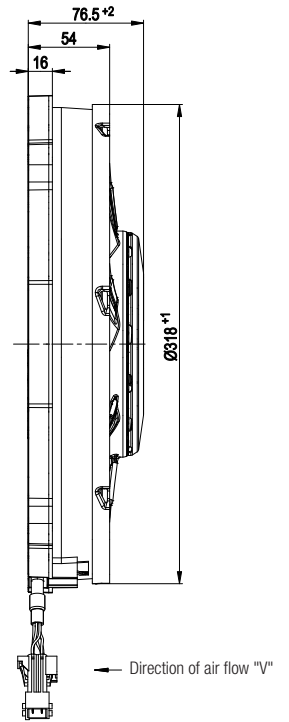
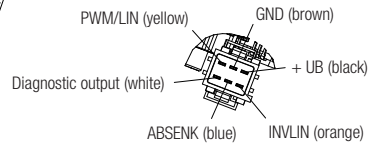
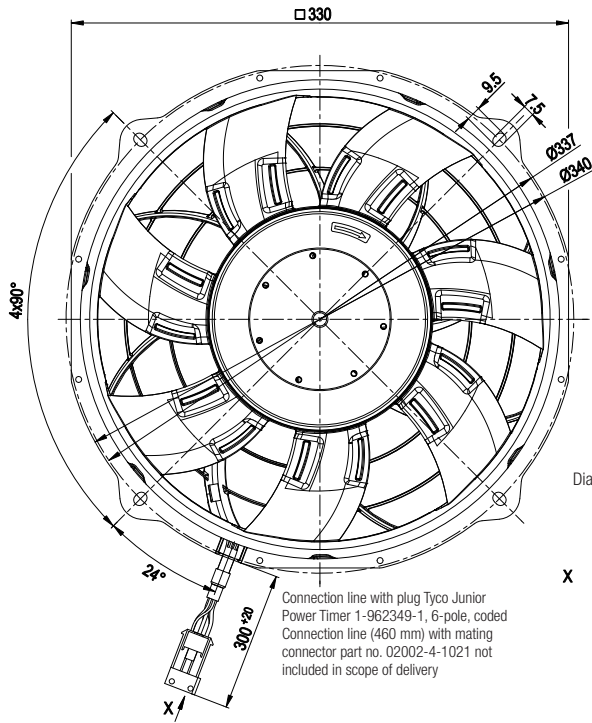

Connection screen

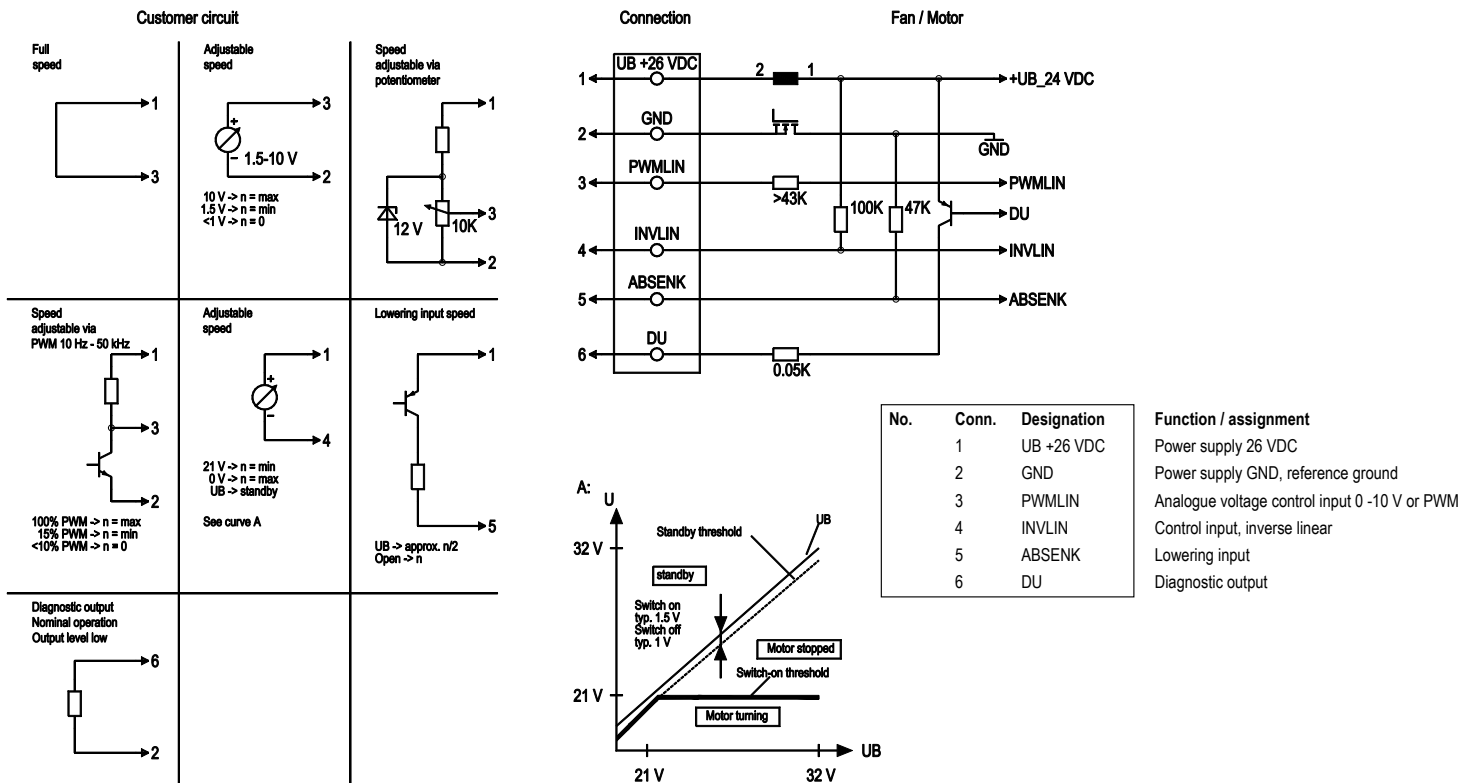

EC axial fan

with brushless DC motor

Fan housing with guide vanes, Automotive

ebm-papst Mulfingen GmbH & Co. KG

Bachmühle 2 · D-74673 Mulfingen

Phone +49 7938 81-0

Fax +49 7938 81-110

info1@de.ebmpapst.com

www.ebmpapst.com

Limited partnership · Headquarters Mulfingen

Amtsgericht (court of registration) Stuttgart · HRA 590344

General partner Elektrobau Mulfingen GmbH · Headquarters Mulfingen

Amtsgericht (court of registration) Stuttgart · HRB 590142

Nominal data

Type	W3G300-ME48-11	
Motor	M3G084-BF	
Nominal voltage	VDC	26
Nominal voltage range	VDC	16 .. 32
Method of obtaining data		fa
Status		prelim.
Speed (rpm)	min ⁻¹	3650
Power consumption	W	320
Current draw	A	12.4
Min. ambient temperature	°C	-40
Max. ambient temperature	°C	70
-with power derating to	°C	85

ml = Max. load · me = Max. efficiency · fa = Free air · cs = Customer specification · ce = Customer equipment
Subject to change

Data according to Commission Regulation (EU) 327/2011

		Actual	Req. 2015
01 Overall efficiency η_{es}	%	54.4	30.9
02 Measurement category		A	
03 Efficiency category		Static	
04 Efficiency grade N		63.5	40
05 Variable speed drive		Yes	

Data obtained at optimum efficiency level.

The ErP data is determined using a motor-impeller combination in a standardized measurement setup.

09 Power consumption P_e	kW	0.36
09 Air flow q_v	m ³ /h	1930
09 Pressure increase p_{fs}	Pa	331
10 Speed (rpm) n	min ⁻¹	3595
11 Specific ratio*		1.00

* Specific ratio = $1 + p_{fs} / 100\,000\text{ Pa}$

LU-199780



Technical description

Weight	2 kg
Size	300 mm
Motor size	84
Blade material	PA plastic
Fan housing material	PP plastic
Number of blades	7
Airflow direction	V
Balancing grade according to DIN ISO 1940-1	G 16
Direction of rotation	Clockwise, viewed toward rotor
Degree of protection	Motor IP24 KM, electronics IP6K9K (mating connector installed)
Insulation class	"B"
Moisture (F) / Environmental (H) protection class	H4
Ambient temperature note	Over +70°C with power derating; Occasional start-up between -40°C and -25°C is permitted. For continuous operation at ambient temperatures below -25°C (such as refrigeration applications), a fan design with special low-temperature bearings must be used.
Max. permitted ambient temp. for motor (transport/storage)	+85 °C
Min. permitted ambient temp. for motor (transport/storage)	-40 °C
Installation position	Any
Mode	S1
Motor bearing	Ball bearing; (sealed)
Life expectancy	40,000 h (typical)
Technical features	<ul style="list-style-type: none"> - Fault output (open collector) - Power limiter - Load dump (58 V) - Motor current limitation - Soft start - Control input 0-10 VDC / PWM - Temperature derating - Thermal overload protection for electronics - Reverse polarity protection
Electrical hookup	Plug; Standby current less than 500 µA
Approval	EAC

EC axial fan

with brushless DC motor

Fan housing with guide vanes, Automotive

Product drawing

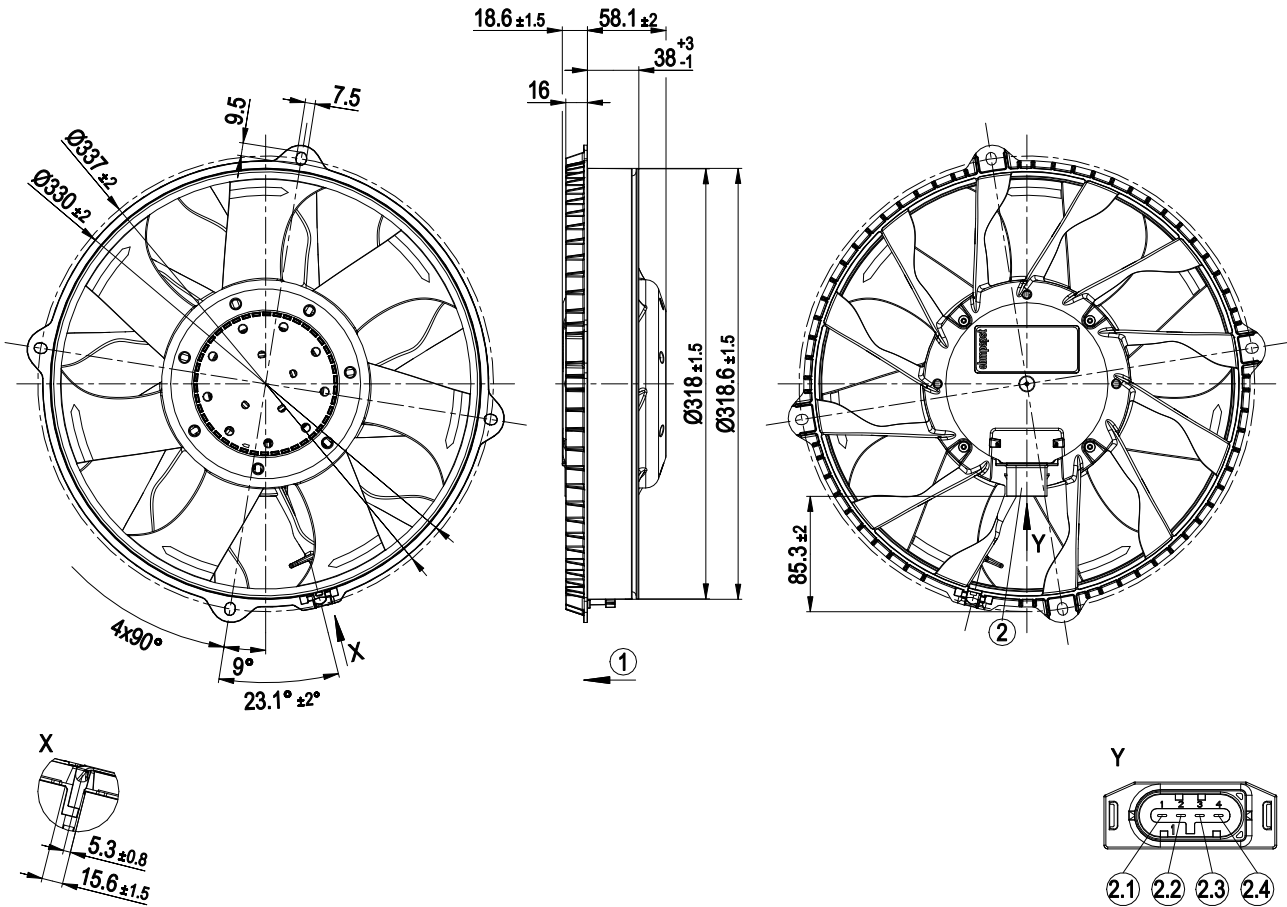

1	Airflow direction "V"
2	4-pole plug, pluggable with cable from accessories
2.1	Diagnostic output
2.2	PWM/LIN
2.3	+ UB
2.4	GND
Accessory part: Cable (460 mm) with mating connector, part no. 02040-4-1021 not included in scope of delivery 4-pole mating connector TE 1-1718628-1, 2x plug contact TE 1-968857-1, 2x plug contact TE 1-968855-1, 2x seal TE 828905-1, 2x seal TE 828904-1	



EC axial fan

with brushless DC motor

Fan housing with guide vanes, Automotive

Connection diagram

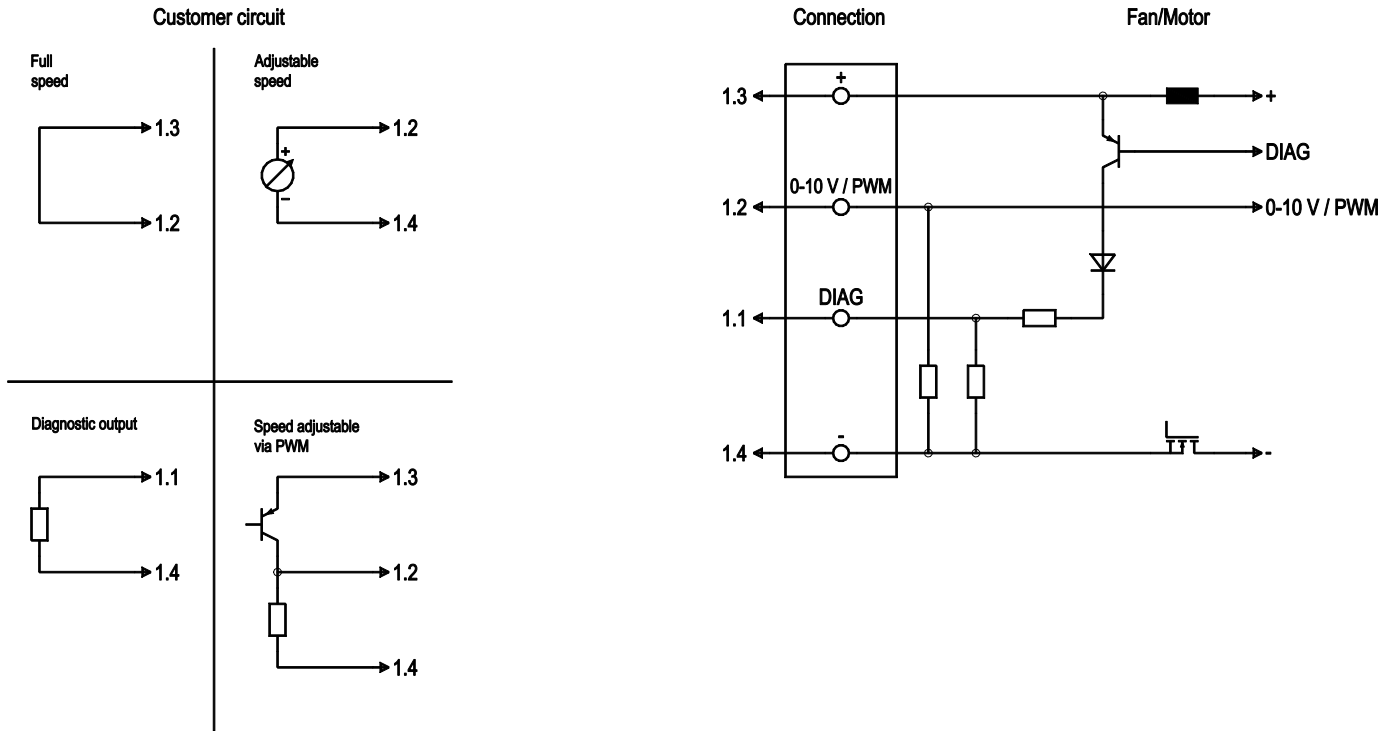

No.	Conn.	Designation	Function/assignment
	1.3	+	Power supply +
	1.4	-	Power supply -
	1.2	0-10 V / PWM	Control input: $R_i > 27\text{ k}\Omega$ 0-10 V: (typ. 0.5 V -> Standby; 1.5 V -> n = min.; 9.5 V -> n = max.) or PWM: (12 V - U_b ; 1 kHz - 10 kHz; typ. < 1% -> standby; 10% -> n = min.; 95% -> n = max.)
	1.1	DIAG	Diagnostic output: Open Collector, $I_{source\ max} = 10\text{ mA}$, $R_{source} = 2\text{ k}\Omega$; $R_{sink} = 100\text{ k}\Omega$ fan OK -> low; fan error -> high



EC axial fan

with brushless DC motor

Fan housing with guide vanes, Automotive

Curves: Air performance

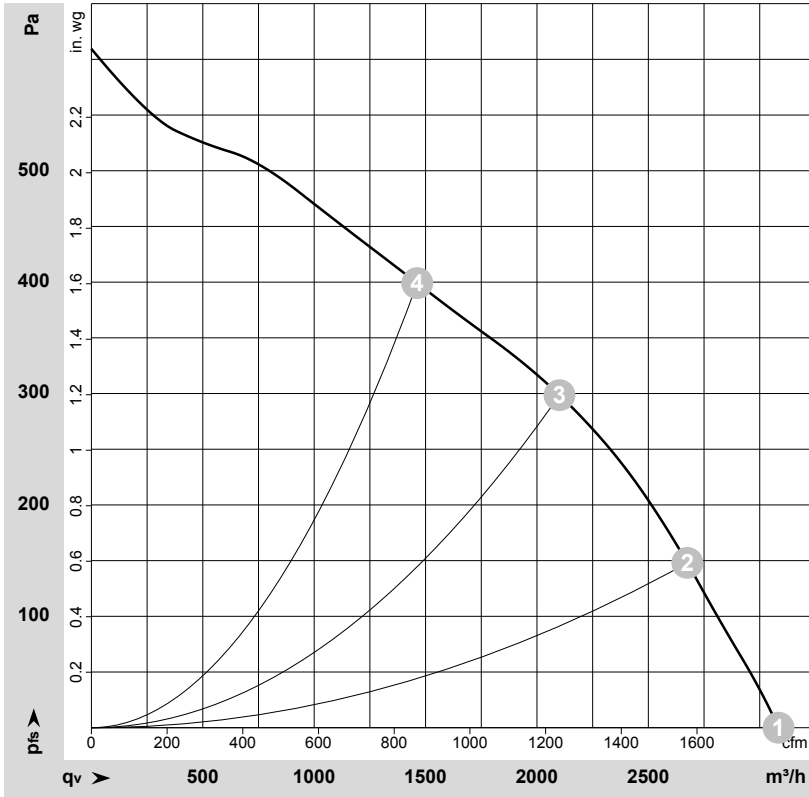

$\rho = 1.15 \text{ kg/m}^3 \pm 2 \%$

Measurement: LU-199780-1

Air performance measured according to ISO 5801 installation category A. For detailed information on the measurement setup, contact ebmpapst. Intake sound level: Sound power level according to ISO 13347 / sound pressure level measured at 1 m distance from fan axis. The values given are valid under the specified measuring conditions and may vary due to conditions of installation. For deviations from the standard configuration, the parameters have to be checked on the installed unit.

Measured values

	U	n	P _{ed}	I	LpA _{in}	LwA _{in}	q _v	p _{fs}	q _v	p _{fs}
	V	min ⁻¹	W	A	dB(A)	dB(A)	m ³ /h	Pa	cfm	in. wg
1	26	3650	320	12.40	80	88	3085	0	1815	0.00
2	26	3650	347	13.33	79	87	2675	150	1575	0.60
3	26	3650	365	14.03	81	88	2100	300	1235	1.20
4	26	3650	376	14.46	84	91	1465	400	860	1.61

U = Voltage · n = Speed (rpm) · P_{ed} = Power consumption · I = Current draw · LpA_{in} = Sound pressure level intake side · LwA_{in} = Sound power level intake side · q_v = Air flow
 p_{fs} = Pressure increase

